

Industrial performance aluminum motors M3AA 200 - 225

Dimension drawings

Foot-mounted motor; IM B3 (IM 1001), IM 1002

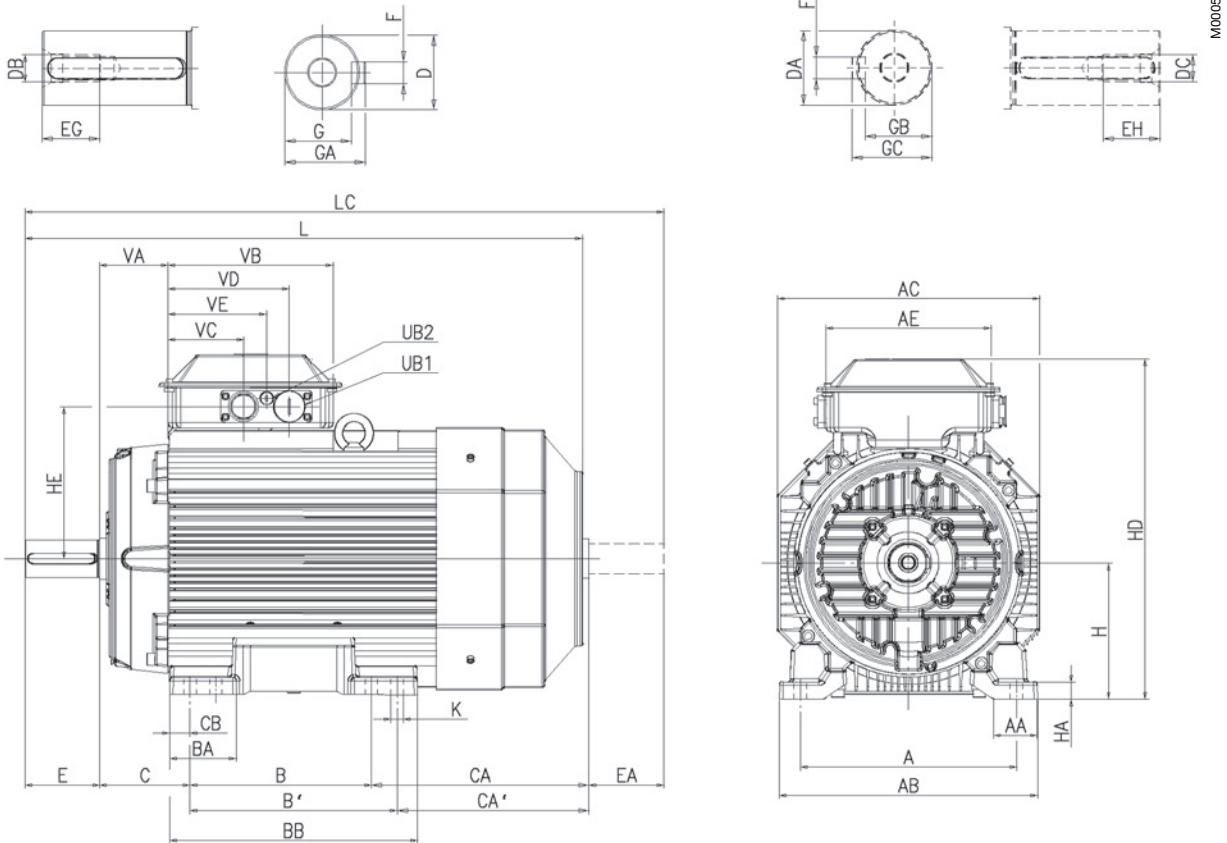

IM B3 (IM 1001), IM 1002

Motor size	A	AA	AB	AC	AE	B	B'	BA	BB	C	CA	CA'	CB	D	DA	DB	DC	E	EA	EG	EH	F	FA
200	318	64	380	386	243	267	305	112	365	133	314	276	30	55	45	M20	M16	110	110	42	36	16	14
225-2 p	356	69	418	425	243	286	311	102	365	149	314	289	24.5	55	55	M20	M20	110	110	42	42	16	14
225 4-8 p	356	69	418	425	243	286	311	102	365	149	314	289	24.5	60	55	M20	M20	140	110	42	42	18	16

Motor size	G	GA	GB	GC	H	HA	HD ²⁾	HD ³⁾	HE ²⁾	HE ³⁾	K	L	LC	UB ¹⁾	VA	VB	VC ²⁾	VC ³⁾	VD ²⁾	VD ³⁾	VE ²⁾	VE ³⁾
200	49	59	39.5	48.5	200	25	500	532	224	239	18	821	934	2xFL13	101	243	112	77	179	167	145	122
225-2 p	49	59	49	59	225	25	547	579	244.5	260	18	850	971	2xFL13	93.5	243	112	77	179	167	145	122
225 4-8 p	53	64	49	59	225	25	547	579	244.5	260	18	880	1001	2xFL13	93.5	243	112	77	179	167	145	122

Tolerances:

A, B	ISO js14
C, CA	± 0.8
D 55-65	ISO m6
DA 45-55	ISO k6
F, FA	ISO h9
H	+0 -0.5

- ¹⁾ Flange opening is provided with pipe flange FL 13, with tapped lead-in holes plugged with sealing plugs.
Single- and two-speed motors: 2 x M40 + M16.
Motors for 230VD 50Hz or 225 SMC-2, 225 SMD-2, 225 SMD-4 have pipe flange FL21 and 2 x M63 + M16
- ²⁾ For flange opening FL13: 2 x M40 + M16
- ³⁾ For extra large flange opening FL21: 2 x M63 + M16

Above table gives the main dimensions in mm.
For detailed drawings please see our web-pages
'www.abb.com/motors&generators'
or contact ABB.

Industrial performance aluminum motors M3AA 200 - 225

Dimension drawings

Flange-mounted motor; IM B5 (IM 3001), IM 3002

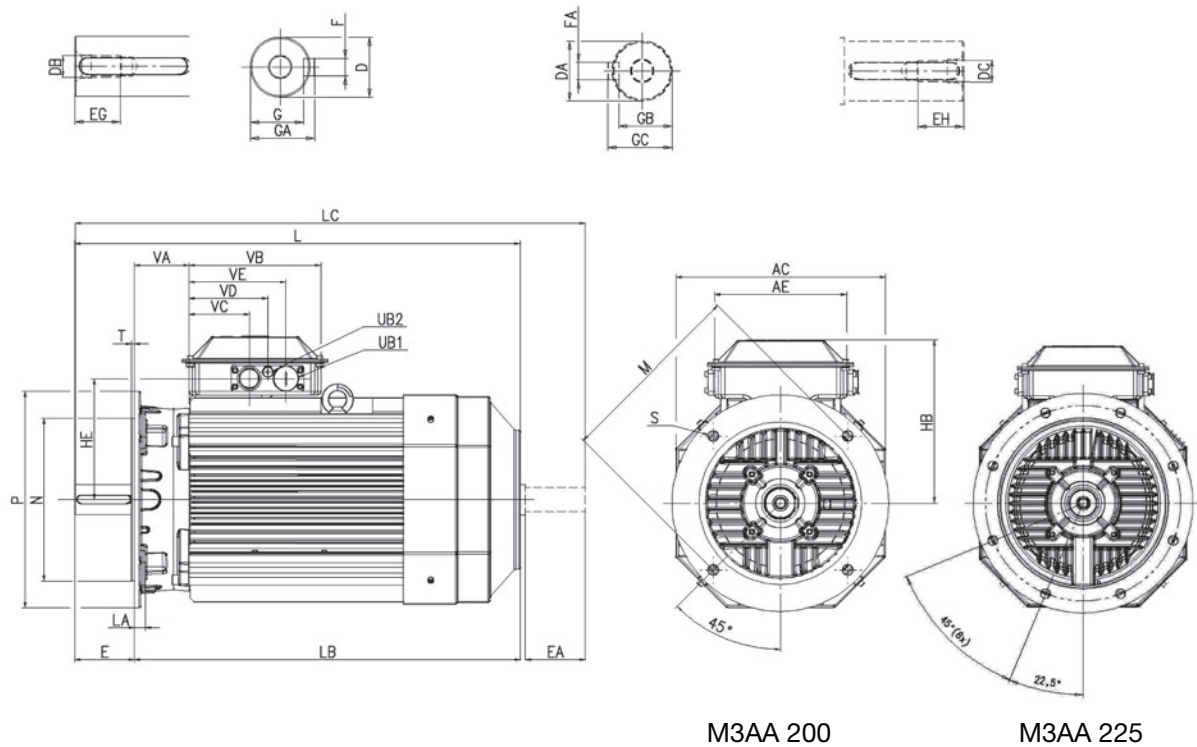

M000518

2

IM B5 (IM 3001), IM 3002

Motor size	AC	AE	D	DA	DB	DC	E ¹⁾	EA	EG	EH	F	FA	G	GA	GB	GC	HB ³⁾	HB ⁴⁾	HE ³⁾	HE ⁴⁾
200	386	243	55	45	M20	M16	110	110	42	36	14	16	49	59	39.5	48.5	300	332	224	239
225-2 p	425	243	55	55	M20	M20	110	110	42	42	16	16	49	59	49	59	300	332	244	260
225 4-8 p	425	243	60	55	M20	M20	140	110	42	42	16	16	53	64	49	59	322	354	244	260

Motor size	L	LA	LB	LC	M	N	P	S	T	UB ²⁾	VA	VB	VC ³⁾	VC ⁴⁾	VD ³⁾	VD ⁴⁾	VE ³⁾	VE ⁴⁾
200	821	20	711	934	350	300	400	19	5	2xFL13	101	243	112	77	179	167	145	122
225-2 p	850	22	740	971	400	350	450	19	5	2xFL13	93.5	243	112	77	179	167	145	122
225 4-8 p	880	22	740	1001	400	350	450	19	5	2xFL13	93.5	243	112	77	179	167	145	122

Tolerances:

D 55-65	ISO m6
DA 45-55	ISO k6
F, FA	ISO h9
N	ISO j6

- ¹⁾ Shoulder of shaft extension and contact surface of flange are in the same plane.
- ²⁾ Flange opening is provided with pipe flange FL 13, with tapped lead-in holes plugged with sealing plugs.
Single- and two-speed motors: 2 x M40 + M16.
Motors for 230VD 50Hz or 225 SMC-2, 225 SMD-2, 225 SMD-4 have pipe flange FL21 and 2 x M63 + M16
- ³⁾ For flange opening FL13: 2 x M40 + M16
- ⁴⁾ For extra large flange opening FL21: 2 x M63 + M16

Above table gives the main dimensions in mm.
For detailed drawings please see our web-pages
www.abb.com/motors&generators
or contact ABB.