



RATHI TRANSPOWER PVT. LTD.
7, DECCAN COLLEGE ROAD, PUNE-411 006 (INDIA)

GEAR-FLEX COUPLING

(RGD / RGS)

CONFORM TO AGMA STANDARD

SUPPLY MANUAL
FOR
ANTARES

GEAR-FLEX COUPLING
(RGD/RGS)

INDEX

<u>CONTENTS</u>	<u>PAGE</u>
• Catalogue	1-4
• Std. Material of Construction	5
• Triple Crowning of Gear Teeth	6
• Ratings for Standard couplings	7
• Customized Gear-flex Specials	8-11
• Lubricants	12
• Selection of Size of Coupling	13
• Typical Service Factors	14-16
• Applications	17
• Std. Tolerances for Finish Bore & Keyway	18
• Punching & Packing Details	19-20
• Quality Assurance Plan (QAP)	21
• Installation Instructions	22-28

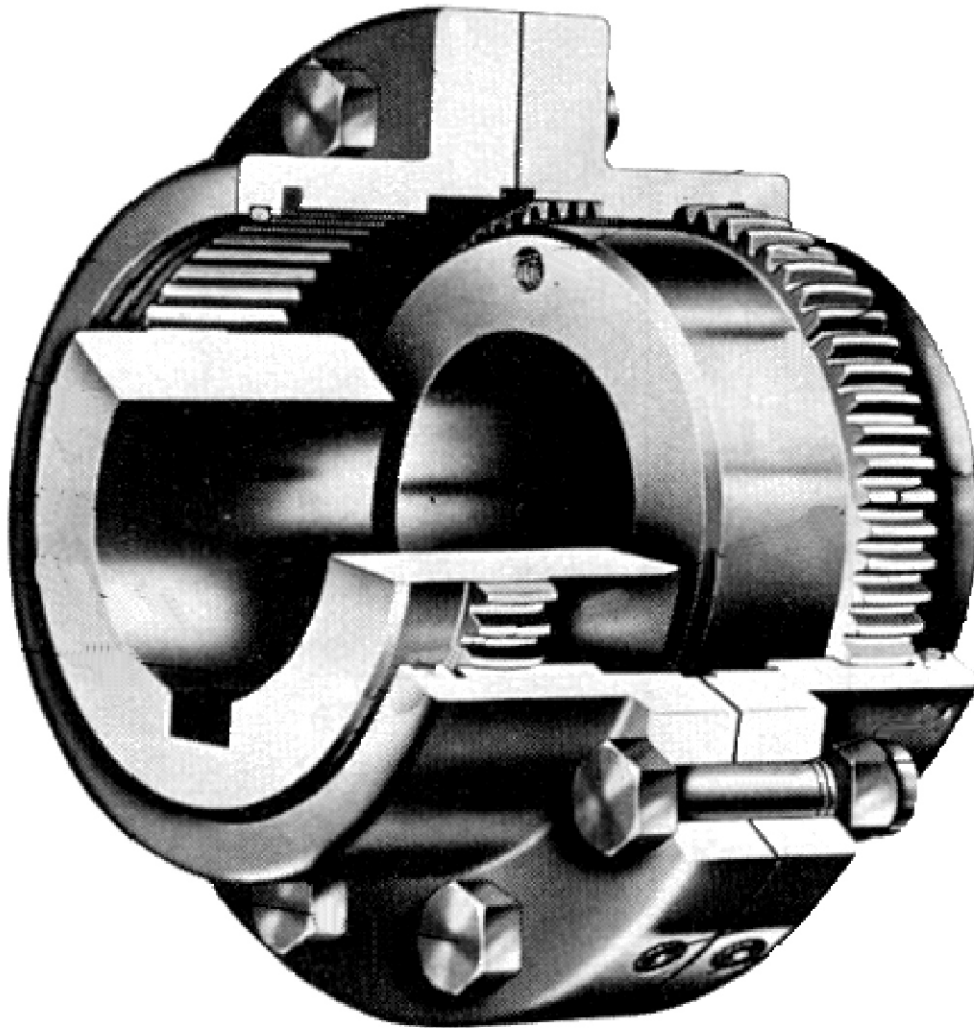
**Features :**

- High Torque Ratings
- Large Bore Capacity
- Interchangeability
- Better Fastener Design
- High Misalignment Capacity
- Improved Lubrication System

**CONFORMS TO
AGMA STANDARD**

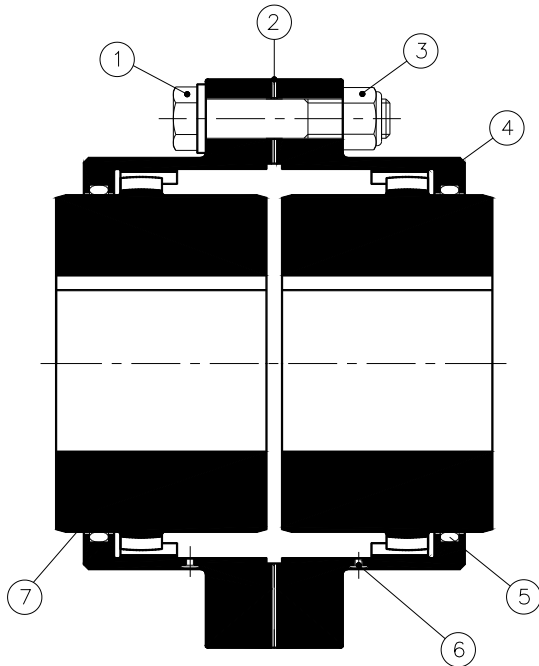

- 1) BOLT
- 2) GASKET
- 3) NUT
- 4) SLEEVE
- 5) O-RING
- 6) PLUG
- 7) HUB

- **High Torque Ratings**
Rathi RGD & RGS Series Gear coupling; torque capacity exceeds the competition, and it allows smaller coupling size of increased service factor.
- **Large Bore Capacity**
Rathi RGD & RGS Series Gear couplings can accommodate large shaft diameters for given particular size of coupling compared to the competition, in most instances. That means you can buy a smaller less expensive coupling and still get the proper rating for the equipment.
- **Interchangeability**
Complete half coupling assemblies are interchangeable with any other half gear coupling with exposed bolt flange manufactured to AGMA standard. Rathi replacement half couplings provide additional hub strength and lower gear mesh loads.
- **High Misalignment Capacity**
Rathi RGD & RGS Gear couplings are designed to accommodate a static misalignment of 1 1/2° per gear mesh. The recommended operating misalignment is limited to 3/4° per gear mesh. Axial moment of connected shafts is also accommodated in these couplings.
- **Lubrication System**
Rathi Special Grease (RSG) properties are designed/developed to resist separation of Base oil & thickener due to centrifugal forces encountered in Gear coupling. This benefits for the application -
 - Significantly extended relubrication intervals
 - Reduced maintenance cost
 - Superior lubrication
 - Increased coupling life

The location & size of lubrication holes in the sleeve ensures that adequate grease is available at the gear mesh, where it is needed must fully moulded seals positively lubricant and seal interior against foreign matter.

Required parameters as per AGMA Standard

Size	10	15	20	25	30	35	40	45	50	55	60	70
Outer Dia.	115.8	152.4	177.8	212.9	239.8	279.4	317.5	345.9	388.9	425.5	457.2	527.1
PCD	95.25	122.25	149.25	181	206.4	241.3	279.4	304.8	342.9	368.3	400.05	463.55
No of Bolts	6	8	6	6	8	8	8	10	8	14	14	16
Hole Dia	1/4"	3/8"	1/2"	5/8"	5/8"	3/4"	3/4"	3/4"	7/8"	7/8"	7/8"	1"
Flange Thk.	14	19	19	22	22	29	29	29	38	38	26	29

SERVICE FACTOR - F

Torque Variation	Electric motor gas or steam turbine	Steam engine or Water turbine	Gas or oil Recip. Engine
Constant Torque e.g. centrifugal pumps and compressors, light fans and light duty agitators	1.0	1.5	3.0
Slight Fluctuations e.g. screw compressors & pumps, liquid ring compressors, medium duty mixer & fans	1.5	2.0	3.0
Substantial Fluctuations e.g. reciprocating pumps, heavy duty mixers & fans.	2.0	2.5	4.0

SELECTION :

1. Select appropriate service factor F.
2. Calculate coupling Torque T (Knm)

$$T = \frac{9.55 \times \text{kW} \times F}{N}$$

Where kW = Drive rated power (kW)
N = Speed (rev./min)
3. Select coupling with the same or higher Torque.
4. Check hub bore capacity.
5. Check allowable speed.

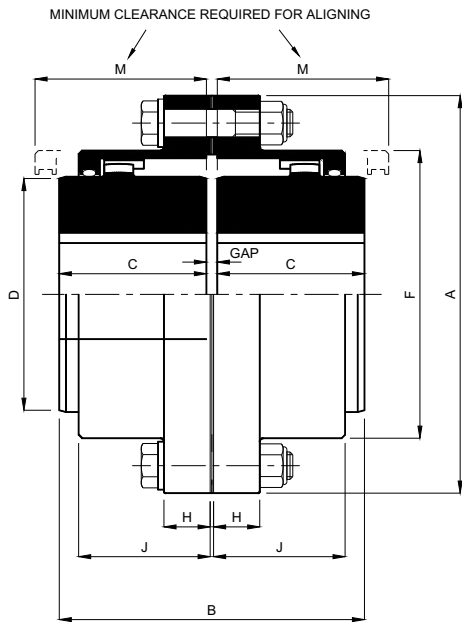

RGD

• **Double Engagement Couplings : TYPE - RGD**

Standard double engagement couplings accommodate both angular and parallel misalignment or combination of both, as well as end float without imposing appreciable axial loads on adjacent bearings.

The exposed bolt design allows use of the either open end or socket wrenches, which makes it the preferred design for most industrial applications.

Ideal for all standard applications including fans, overhead cranes, conveyors, steel and paper mill equipment.

Special requirements like limited end float, electrical insulation, Mill motor, Slide, Spacer, Brake drum, Shear pin, designs are possible. Many designs can be created for "Unique" applications as well, contact RATHI.

Coupling Size	Coupling Rating		Maximum Speed rpm	Bore Dia mm		DIMENSIONS mm										Mass kg	MR ² Inertia kg m ²
	kW at 100rpm	Rated Torque KNm		Min Bore	Max Bore	A	B	C	D	F	H	J	M	Gap			
10	12.5	1.2	8000	12	52	116	89	43	69	84	14	39	51	3	4.4	0.0052	
15	26.1	2.5	6500	20	65	152	102	50	86	105	19	48	61	3	9	0.0192	
20	52.1	5	5600	25	80	178	127	62	105	127	19	60	76	3	15	0.041	
25	90.7	8.7	4035	30	98	213	159	77	131	155	22	72	92	5	27	0.105	
30	134.4	12.9	3580	40	115	240	187	91	152	181	22	84	106	5	40	0.195	
35	202.2	19.4	3080	45	135	279	219	107	178	211	29	98	130	6	65	0.454	
40	317.9	30.5	2700	45	160	318	247	121	210	246	29	111	145	6	96	0.86	
45	435.6	41.8	2480	50	180	346	278	135	235	274	29	123	165	8	131	1.39	
50	594	57	2210	70	195	389	314	153	254	306	38	141	183	8	186	2.53	
55	844.1	81	2020	70	215	425	344	168	279	334	38	158	203	8	247	3.63	
60	990	95	1880	75	235	457	384	188	305	366	26	169	228	8	299	5.21	
70	1531	147	1630	90	280	527	451	221	356	425	29	196	266	10	473	11	

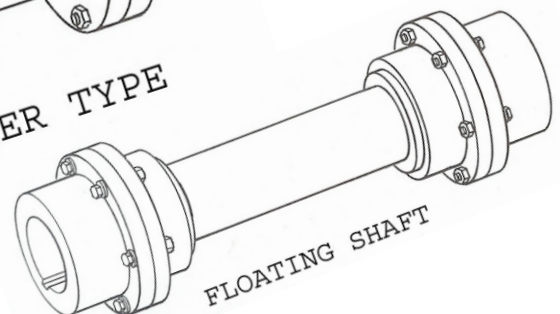
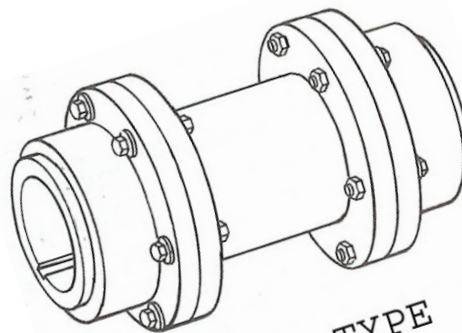
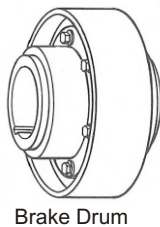
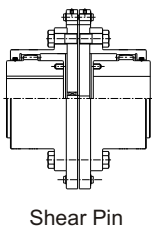
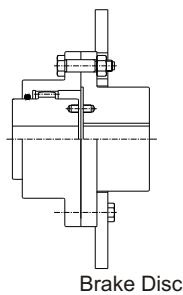
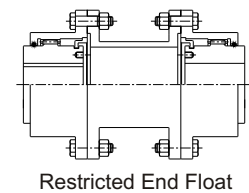

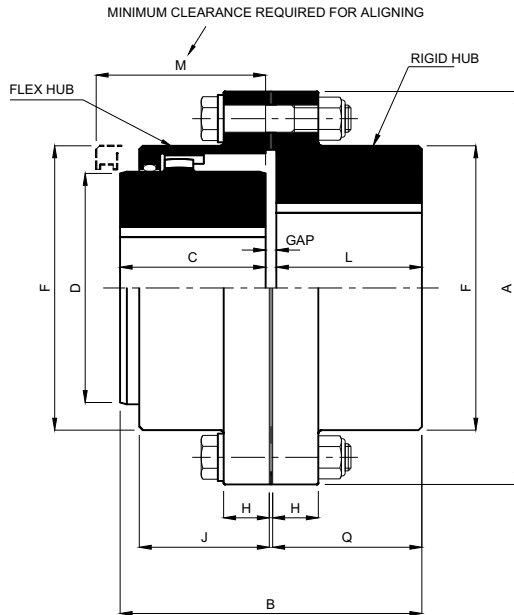

RGS

● **Single Engagement Couplings : TYPE - RGS**

Standard single engagement couplings accommodate angular misalignment and end float without imposing appreciable axial loads on adjacent bearings.

Exposed bolt design allows use of the either open end or socket wrenches, which makes it the preferred design for most industrial applications.

Used primarily with floating shaft assemblies to cover longer distance between shaft ends. Consult RATHI for vertical application.

Coupling Size	Coupling Rating		Maximum Speed rpm	Min Bore mm	Max Bore Dia mm		DIMENSIONS mm										Mass kg	MR ² Inertia kg m ²	
	kW at 100rpm	Rated Torque KNm			Flex Hub	Rigid Hub	A	B	C	D	F	F1	H	J	L	M			Gap
10	12.5	1.2	8000	12	52	60	116	87	43	69	84	84	14	39	40	51	4	4.5	0.0055
15	26.1	2.5	6500	20	65	80	152	100	50	86	105	107	19	48	47	61	4	9.5	0.0204
20	52.1	5	5600	25	80	90	178	125	62	105	127	130	19	60	59	76	4	15.5	0.0436
25	90.7	8.7	4035	30	98	110	213	156	77	131	155	157	22	72	74	92	5	27.5	0.111
30	134.4	12.9	3580	40	115	130	240	184	91	152	181	182	22	84	88	106	5	41.5	0.21
35	202.2	19.4	3080	45	135	150	279	215	107	178	211	212	29	98	102	130	6	67	0.477
40	317.9	30.5	2700	45	160	180	318	244	121	210	246	250	29	111	116	145	8	100	0.92
45	435.6	41.8	2480	50	180	200	346	274	135	235	274	276	29	123	131	165	8	135	1.468
50	594	57	2210	70	195	220	389	310	153	254	306	309	38	141	148	183	9	195	2.73
55	844.1	81	2020	70	215	240	425	350	168	279	334	334	38	158	173	203	9	261	4.2
60	990	95	1880	75	235	260	457	385	188	305	366	366	26	169	187	228	10.5	316	5.7
70	1531	147	1630	90	280	300	527	454	221	356	425	425	29	196	220	266	13	500	12.05

- The outer dimensions of flanges are rounded up to nearest figure in above tables.
- Contact RATHI for couplings operating at higher torques upto 8100 kNm and higher speeds than specified.
- To attend the max. speed specified above Dynamic balancing is required please Consult RATHI.
- Max. bores specified above are for uniformly loaded drives only.
- Max. bore for coupling with or equivalent to DIN 6885 keys.
- Min. bore is nothing but a rough stock bore, to which the couplings are manufactured.
- Spacer type couplings are available, Contact to RATHI.
- Weight and Moment of Inertia (Wk²) are with solid hubs.
- Higher sizes are available on request. Contact to RATHI.

● In view of our constant endeavour to improve the quality of our products, we reserve the right to alter or change specifications without prior notice.
 ● This document is an intellectual property of Rathi Transpower Pvt. Ltd. and subject to copyright.

	<p>Rathi Transpower Pvt Ltd Rathi Chambers, 7, Deccan College Road, Pune 411 006. Phone : 020-26696820, 26694826, 26697032 Fax : 020-26695655 E-mail : info@rathigroup.com Website : www.rathitranspower.com</p>	<p>Distributor</p>
--	---	---------------------------

**GEAR-FLEX COUPLING
(RGD/RGS)**

RGD / RGS - MATERIALS SPECIFICATION

Fig. 1

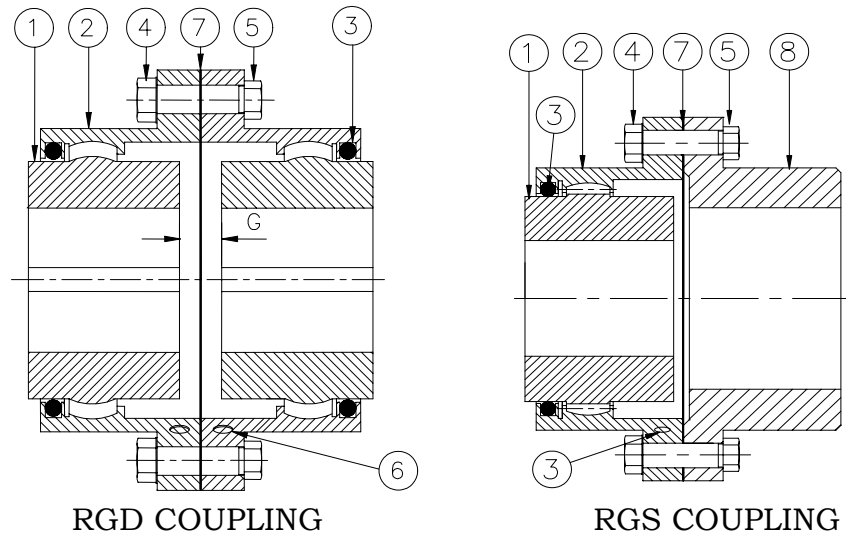

RGD / RGS Materials :

- | | | |
|----|---------------|-------------------------------|
| 1. | Hubs | : EN-9 BS 970 |
| 2. | Sleeves | : Cast Steel – SAE J435c |
| 3. | Seal | : Nitrile Rubber (SH – 60° A) |
| 4. | Bolts | : (Hardened) EN-8 BS 970 |
| 5. | Nuts | : Sts. As per BS 1083 |
| 6. | Grease nipple | : Std. |
| 7. | Gasket | : Paronite Paper |
| 8. | Rigid Hub | : EN-9 BS 970 |

GEAR-FLEX COUPLING (RGD/RGS)

TRIPLE CROWNING OF GEAR TEETH

The straight-line tooth form is known to transmit high torque when the centres of axis are in complete alignment. Where there is any displacement, however, this will cause the contact area to localize on tooth surface (at the end of tip of the tooth) thereby causing damage to surfaces of the teeth.

While rotating the load is continually changing location, introducing sliding between the two gears. Crowned gear teeth resist the wear thus developed. Because of the fully crowned design, end bearing does not occur, and the tooth bearing remains near the centre section of the tooth, thus utilizing the additional strength available at the tooth centre.

Fig. 2

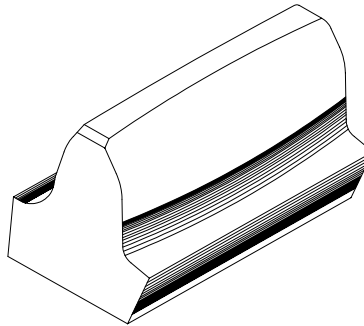

TRIPPLE CROWNED TOOTH

The RATHI Gear coupling has a unique crowning for the tooth surface, which is designed after full consideration of the relationship between tooth forms & tooth width so that the contact stress on the tooth surface will not vary significantly even where relative movement is present. As for the tooth tip, the crowning is applied & the tooth is designed to minimise the top clearance between teeth when they are mated.

The RATHI Gear coupling has a crown tooth form so as to give maximum tooth thickness at its centre. Where there is a relative misalignment between the driver & driven shaft, it is necessary that the tooth, which comes between the teeth of its counterpart, be permitted to oscillate. The internal teeth of the sleeves have a std. form whereas the external teeth of the hub take a special form.



GEAR-FLEX COUPLING
(RGD/RGS)

RGD / RGS - RATINGS FOR STANDARD COUPLING

Sr. No.	Coupling Size (RGD/RGS)	Rated Torque			Rated Power			
		Nm	kg m	Lbs-inch	@100 RPM		@1500 RPM	
					Kw	HP	Kw	HP
1	10	1200	122.365	10620.9	12.5	16.762	187.5	251.44
2	15	2500	254.929	22126.88	26.1	35.000	391.5	525.00
3	20	5000	509.858	44253.75	52.1	69.867	781.5	1048.00
4	25	8700	887.153	77001.52	90.7	121.63	1360.5	1824.46
5	30	12900	1315.434	114174.4	134.4	180.230	2016.0	2703.50
6	35	19400	1978.249	171704.5	202.2	271.154	3033.0	4067.32
7	40	30500	3110.134	269947.9	317.9	426.310	4768.5	6394.66
8	45	41800	4202.414	369961.3	435.6	584.149	6534.0	87620.23
9	50	57000	5812.382	504492.8	594.0	796.567	8510.0	11948.51
10	55	81000	8259.701	716910.8	844.1	1131.957	12661.5	16979.35
11	60	95000	9687.304	840821.3	990.0	1327.610	14850.0	19914.18
12	70	147000	14899.83	130106.0	1531.0	2053.105	22905.0	30716.11

GEAR-FLEX COUPLING
(RGD/RGS)

CUSTOMISED GEAR-FLEX SPECIALS

1. Floating shaft couplings
(Fig. 3a & 3b)
2. Spacer couplings
(Fig. 4a & 4b)
3. RGD - Type Couplings with one hub reversed
(Fig. 5)
4. RGD - Type Couplings with both hub reversed
(Fig. 6)
5. RGS - Type with flexible hub reversed
(Fig. 7)
6. Couplings with cut off hubs
(Fig. 8)

GEAR-FLEX COUPLING (RGD/RGS)

1) RGS - COUPLINGS WITH FLOATING SHAFTS

A floating shaft can eliminate the need for additional bearing support along spanning shaft because shaft is supported at ends by connected equipment through the half flex couplings. These are generally used for the applications of cooling tower fans.

Flexible hubs on floating shaft (Fig. 3a)

Assembly of flexible hubs on the floating shaft allows for easier replacement in case of wear & allows the rigid hubs with their increased bore capacities to be used on the connected equipment shafts. This frequently means a smaller coupling size to be utilised.

Fig. 3a

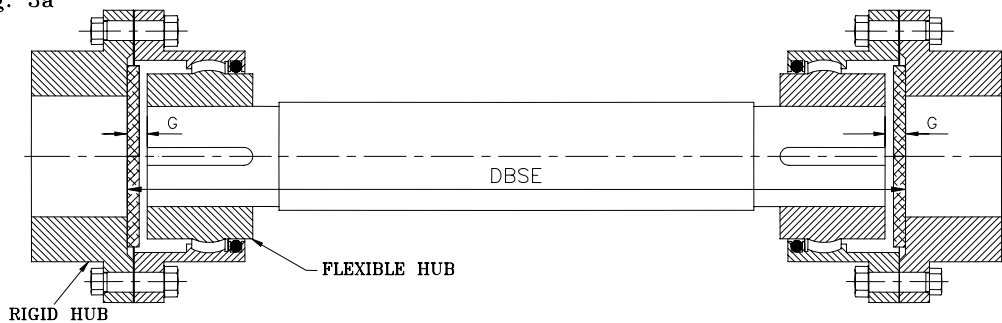

Rigid hubs on floating shaft (Fig. 3b)

When the rigid hubs are on floating shaft, shorter shaft spans can be accommodated. Since the flexible hubs are outboard, the planes of gear mesh are outboard, providing greater misalignment capacity.

Fig. 3b

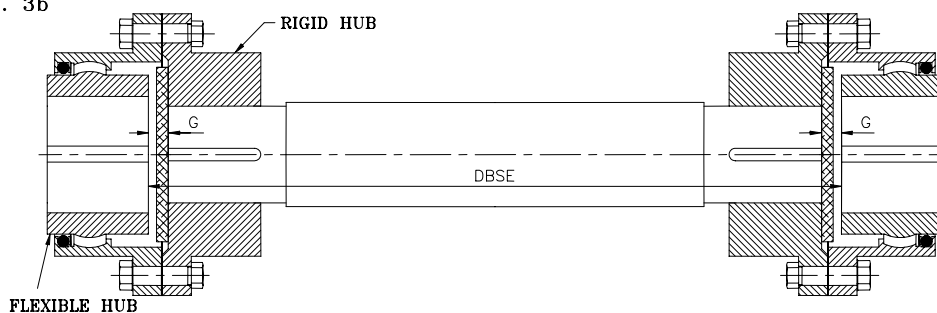

GEAR-FLEX COUPLING
(RGD/RGS)

2) RGD/RGS - SPACER COUPLINGS

Used on pumps & compressors for ease of servicing without disturbing either of the shafts.

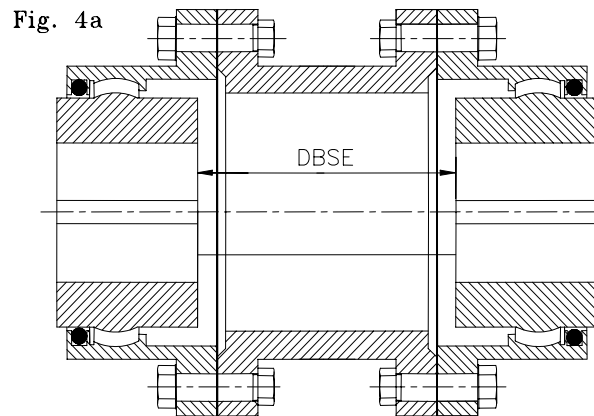

TYPE RGD – SPACER COUPLING

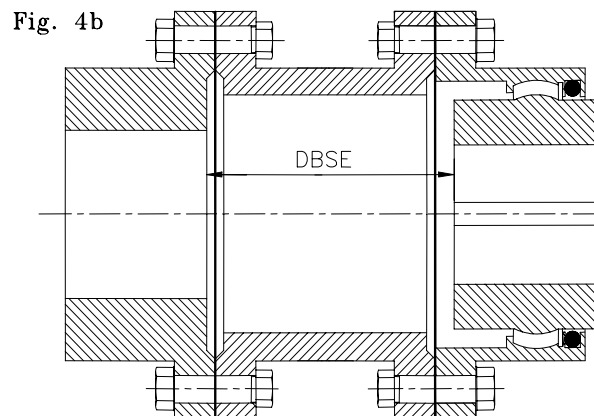

TYPE RGS – SPACER COUPLING

GEAR-FLEX COUPLING
(RGD/RGS)

3) RGD / RGS REVERSED HUBS COMBINATIONS

1. RGD - ONE HUB REVERSED

Fig. 5

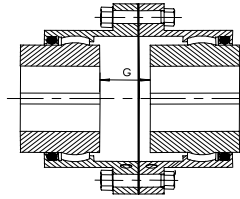

2 . RGD - BOTH HUBS REVERSED

Fig. 6

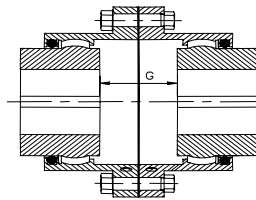

3. RGS - FLEX. HUB REVERSED

Fig. 7

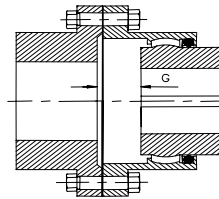

4. RGD - LONG HUB CUT OFF

Fig. 8

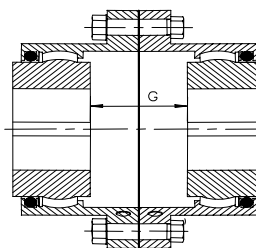

GEAR-FLEX COUPLING
(RGD/RGS)

SELECTION OF SIZE OF COUPLING

Requirements

Application : Driver -
 Driven -

Application Rating : kW - RPM -

Shaft sizes : Driver - Driven -

Distance between shaft ends (DBSE) if reqd. :

Service Factor (S.F.) to be taken :

Selection Procedure

(a) Service Factor

Determine appropriate SERVICE FACTOR from table

(b) Design Power

Multiply running power of driven machinery by the service factor. This gives DESIGN POWER which is used as a basis for coupling selection.

(c) Coupling Size

Refer to rating table for your required coupling size and read from the appropriate speed column until a power equal to or greater than the DESIGN POWER is found.

(d) Bore Size

Refer respective coupling dimensional table to check that the required bores can be accommodated. If bore size of selected coupling can't accommodate the shaft size, then go for next coupling size where shaft size can be accommodated.



GEAR-FLEX COUPLING (RGD/RGS)

TYPICAL SERVICE FACTORS

Values listed are intended only as a general guide, and are typical of usual service requirements. For systems which frequently utilize the peak torque capability of the power source, verify that the magnitude of this peak torque does not exceed the 1.0 Service Factor Rating of the coupling selected. Applications which involve extreme repetitive shock or high-energy load absorption characteristics should be referred - with full particulars - to GEAR-FLEX.

Values contained in the table are to be applied to smooth power sources such as electric motors and steam turbines. For drives involving internal combustion engines of four or more cylinders, add 1.0 to the values listed, for six or more cylinders, add 0.5 to the values listed.

Application	Typical Service Factor	Application	Typical Service Factor
AGITATORS		DREDGES	
Pure Liquids	1	Cable Reels	1.75
Liquids & Solids	1.25	Conveyors	1.5
Liquids-Variable Density	1.25	Cutter Head Jig Drives	2.5
BLOWERS		Maneuvering Winches	1.75
Centrifugal	1	Pumps	1.75
Lobe	1.5	Screen Drives	1.75
Vane	1.25	Stackers	1.75
BRIQUETTE MACHINES		Utility Winches	1.5
CAR PULLERS-Intermittent Duty	1.5	ELEVATORS	
CLAY WORKING MACHINERY	1.75	Bucket	1.75
COMPRESSORS		Centrifugal & Gravity Discharge	1.5
Centrifugal	1	Escalators	1.5
Centriaxial	1.25	Freight	2.5
Lobe	1.5	FANS	
Reci-procating-Multi Cylinder	2	Centrifugal	1
CONVEYORS-Light Duty Uniformly Fed		Cooling Towers	1.5
Apron, Bucket, Chain, Flight, Screw	1.25	Forced Draft	1.5
Assembly, Belt	1.25	Induced Draft without Damper	
Oven	2.5	Control	2
CONVEYORS-Heavy Duty		FEEDERS	
Not Uniformly Fed		Apron, Belt, Disc, Screw	1.25
Apron, Bucket, Chain, Flight, Oven	1.5	Reciprocating	2.5
Assembly, Belt	1.25	GENERATORS-	
Reciprocating Shaker	2.5	(Not Welding)	1
CRANES AND HOISTS		HAMMER MILLS	
Main Hoists, Reversing	2.5	LAUNDRY WASHERS	
Skip Hoists, Trolley & Bridge Drives	2	Reversing	2
Slope	2	LAUNDRY TUMBLERS	
CRUSHERS		LINE SHAFT	
Ore Stone	3		1.5



**GEAR-FLEX COUPLING
(RGD/RGS)**

TYPICAL SERVICE FACTORS

Application	Typical Service Factor	Application	Typical Service Factor
LUMBER INDUSTRY		METAL ROLLING MILLS	
Barkers-Drum Type	2	Coilers, hot mill	2
Edger Feed	2	Coilers, cold mill	1.5
Live Rolls	2	Cold Mills	2
Log Haul-Incline	2	Cooling Beds	1.75
Log Haul-Well Type	2	Door Openers	2
Off bearing Rolls	2	Draw Benches	2
Planer Feed Chains	1.75	Edger Drives	1.75
Planer Floor Chains	1.75	Feed Rolls, Reversing Mills	3.5
Planer Tilting Hoist	1.75	Furnace Pushers	2.5
Slab Conveyor	1.5	Hot Mills	3
Sorting Table	1.5	Ingot Cars	2.5
Trimmer Feed	1.75	Kick-outs	2.5
MACHINE TOOLS		Manipulators	3
Bending Roll	2	Merchant Mills	3
Plate Planer	1.5	Piercers	3
Punch Press-Gear Driven	2	Pusher Rams	2.5
Tapping Machines	2.5	Reel Drives	1.75
Other Machine Tools		Reel Drums	2
Main Drives	1.5	Reelers	3
Auxiliary Drives	1.25	Rod and Bar Mills	3
METAL MILLS		Roughing Mill Delivery Table	3
Draw Bench-Carriage	2	Runout Tables	2.5
Draw Bench-Main Drive	2	Saws, hot & cold	2.5
Forming Machines	2	Screwdown Drives	3
Slitters	1.5	Skelp Mills	3
Table Conveyors		Slitters	3
Non-reversing	2.25	Slabbing Mills	3
Reversing	2.5	Soaking Pit Cover Drives	3
Wire Drawing & Flattening Machine	2	Straighteners	2.5
Wire Winding Machine	1.75	Tables, transfer & runout	2.5
MILLS, ROTARY TYPE		Thrust Block	3
Ball	2.25	Traction Drive	3
Dryers & Coolers	2	Tube Conveyor Rolls	2.5
Hammer	1.75	Unscramblers	2.5
Kilns	2	Wire Drawing	1.75
Pebble & Rod	2	PRINTING PRESSES	
Pug	1.75	PULLERS-Barge Haul	
Tumbling Barrels	2	OIL INDUSTRY	
MIXERS		Chillers	1.25
Concrete Mixers	1.75	Paraffin Filter Press	1.75
Drum Type	1.5		



**GEAR-FLEX COUPLING
(RGD/RGS)**

TYPICAL SERVICE FACTORS

Application	Typical Service Factor	Application	Typical Service Factor
RUBBER INDUSTRY		PUMPS	
Mixed-Banbury	2.5	Centrifugal	1
Rubber Calender	2	Reciprocating	
Rubber Mill (2 or more)	2.25	Single Acting	
Sheeter	2	1 or 2 Cylinders	2.25
Tire Building Machines	2.5	3 or more Cylinders	1.75
Tire & Tube Press Openers	1	Double Acting	2
Tubers & Strainers	2	Rotary, Gear, Lobe, Vane	1.5
PAPER MILLS		SCREEN	
Barker Auxiliaries, Hydraulic	2	Air Washing	1
Barker, Mechanical	2	Grizzly	2
Barking Drum Spur Gear Only	2.25	Rotary-Stone or Gravel	1.5
Beater & Pulper	1.75	Traveling Water Intake	1.25
Bleacher	1	Vibrating	2.5
Calenders	2	SEWAGE DISPOSAL EQUIPMENT	
Chippers	2.5	Bar Screens	1.25
Coaters	1	Chemical Feeders	1.25
Converting Machines, except		Collectors, Circuline or Straighttime	1.25
Cutters, Platers	1.5	Dewatering Screens	1.25
Couch Roll	1.75	Grit Collectors	1.25
Cutters, Platers	2	Scum Breakers	1.25
Cylinders	1.75	Slow or Rapid Mixers	1.25
Disc Refiners	1.75	Sludge Collectors	1.25
Dryers	1.75	Thickeners	1.25
Felt Stretcher	1.25	Vacuum Filters	1.25
Felt Whipper	2	STEERING GEAR	
Jordans	1.75	STOKERS	
Line Shaft	1.5	WINCH	
Log Haul	2	WINDLASS	
Pulp Grinder	1.75		1.75
Press Roll	2		
Reel	1.5		
Stock Chests	1.5		
Suction Roll	1.75		
Washers & Thickeners	1.5		
Winders	1.5		

GEAR-FLEX COUPLING
(RGD/RGS)

APPLICATIONS

Gear-flex couplings can be used effectively & economically for transmission of mechanical power for :

Agitators	Hammer mills
Blowers	Line shafts
Conveyors	Machine tools
Crushers	Metal forming machines
Elevators	Mixers
Escalators	Pulverisers
Extruders	Pumps
Feeders	Screens
Generators	Wenches

In industries like

- Cement Brewing & Distilling Food
- Rolling Mills
- Oil & Petroleum
- Chemical & Fertiliser
- Paper Mills
- Rubber
- Sewage Disposal, Sugar, Textile
- Thermal Power Houses

GEAR-FLEX COUPLING (RGD/RGS)

STANDARD TOLERANCES FOR FINISH BORE & KEYWAY

Unless otherwise specified, couplings are supplied with finish bore & keyway in H7 & JS9 tolerances respectively as per standard IS 919 (part 2) : 1993.

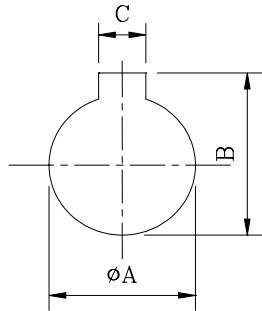

ϕA - Bore
 B - Keyway Depth
 C - Keyway Width

Basic Size (mm.)		H7 For Bores (mm.)	JS9 For Keyway Width (mm.)	For Keyway Depth (mm.)
Above	Upto & including			
3	6	+ 0.012 0	± 0.015	+ 0.1 0
6	10	+ 0.015 0	± 0.018	
10	18	+ 0.018 0	± 0.021	
18	30	+ 0.021 0	± 0.026	+ 0.2 0
30	50	+ 0.025 0	± 0.031	
50	80	+ 0.030 0	± 0.037	
80	120	+ 0.035 0	± 0.043	
120	180	+ 0.040 0	± 0.050	+ 0.3 0
180	250	+ 0.046 0	± 0.057	
250	315	+ 0.052 0	± 0.065	+ 0.4 0

GEAR-FLEX COUPLING
(RGD/EGS)

PUNCHING & PACKING DETAILS

Punching of RGD/RGS Coupling.

Each coupling is punched as per enclosed drawing **R/G-2312**.

Packing of RGD/RGS coupling.

Each Coupling is packed in polythene bag in assembled condition. Finish bore Coupling are with grease applied in finish bore to prevent corrosion.

This is then packed in a Corrugated Box with metallic base.

DO NOT SCALE

ALL DIMENSIONS ARE IN mm.

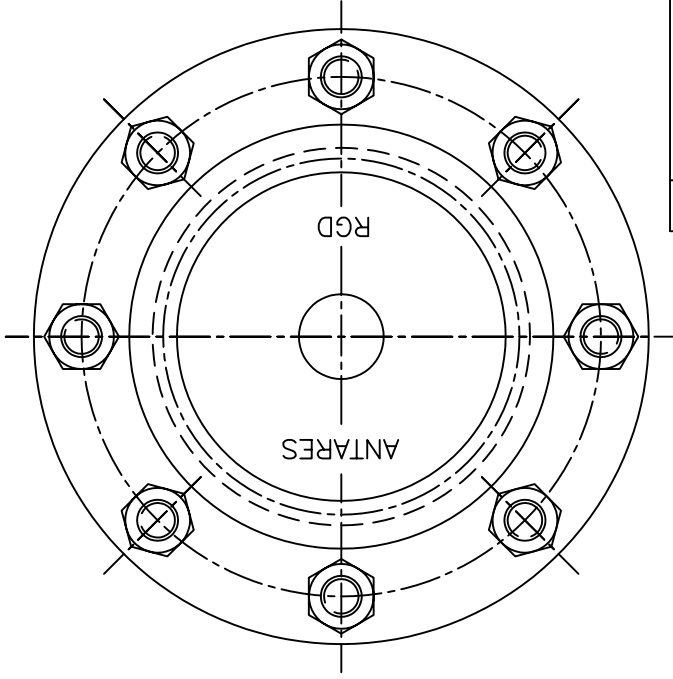
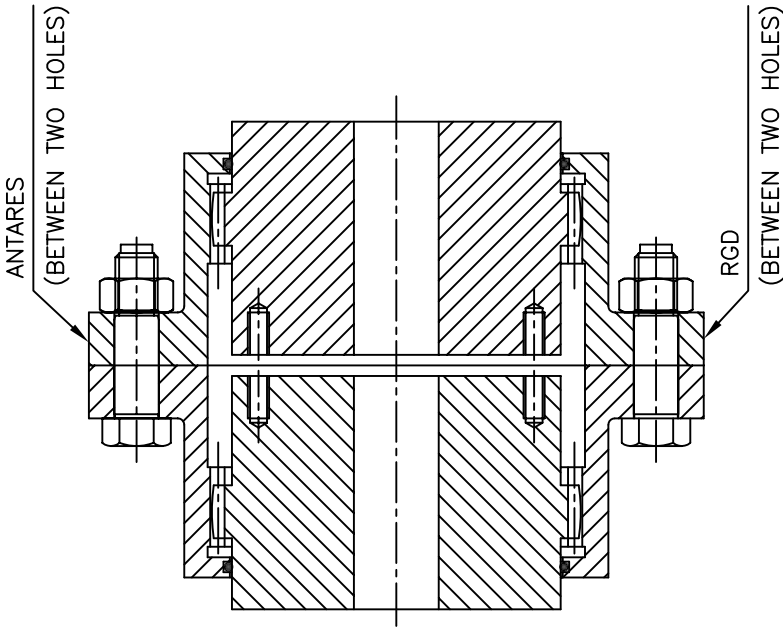

SR. NO.	COUPLING SIZE	LETTER HEIGHT
1	10, 15, 20, 25	3 mm
2	30, 35, 40	5 mm
3	45, 50, 55, 60, 70	8 mm

△ PROCESS SEQUENCE :-

- 1) PHOSPHATING
- 2) PUNCHING / MARKING AS PER THIS DRAWING.
- 3) PAINTING – GOLDEN YELLOW
- 4) ASSEMBLY

TITLE: RGD MARKING DETAIL

MATERIAL : _____	
TRACED	NAME
DRAWN	DATE
CHECKED	URK
APPROVED	YAM
REF. NO	YAM
DATE	19/12/06
SCALE : NTS	19/12/06
PROCESS SEQUENCE	23/12/06
DMRN5580	23/12/06
1 DDB	DATE
REV SIGN	ALTERATION
RAHI	
RATHI TRANSPOWER PVT LTD	
PUNE 411006	
DRG.NO. R/G-2312/1	

**GEAR-FLEX COUPLING
(RGD/RGS)**

QUALITY ASSURANCE PLAN (QAP)

Sr. No.	Item	Parameters to Check	Extent of Check & Frequency	Instruments to be Used
A) RAW MATERIAL (Material Control)				
1)	Forged Steel	1. Visual Defects, 2. Material Test certificate from Suppliers 3. Hardness	100% Every Batch Sampling	Hardness Testing M/C
2)	Cast Steel	1. Visual Defects, 2. Material Test certificate from Suppliers 3. Hardness	100% Every Batch Sampling	Hardness Testing M/C
3)	Bolts	1. Visual Defects, 2. Material Test certificate from Suppliers 3. Hardness	100% Every Batch Sampling	Hardness Testing M/C
4	Nuts	Standard Make, Size & Grade	Sampling	
5)	Seal	1. Visual Defects 2. Overall Dimensions 3. Shore Hardness	100% Sampling Sampling	Vernier Shore Hardness Tester
B) MACHINING (Process Control)				
1)	Hub	1. Overall Dimensions 2. Gear Teeth Cutting	Sampling after every stage	Vernier & Micrometer Pin Gauge & Micrometer
2)	Sleeve	1. Overall Dimensions 2. Gear Teeth Cutting	Sampling after every stage	Vernier & Micrometer Pin Gauge & Micrometer
C) FINISH BORE				
1)	Hub	Finish Bore	Sampling	Plug Gauge / Bore Gauge
D) KEYWAY				
1)	Hub	Keyway Width & Depth	Sampling	Slip Gauge & Vernier

**Sample size is : 5 upto 100
10 upto 500.**

GEAR-FLEX COUPLING
(RGD/RGS)

INSTALLATION INSTRUCTIONS
FOR STD. RGD / RGS COUPLINGS

(A) BEFORE INSTALLATION

1. Remove the coupling from packing & thoroughly inspect for signs of damage.
2. Disassemble the coupling by removing nuts & bolts. Clean all the parts carefully.
3. Remove protective coatings / lubricants from bores & keyways.

(B) MOUNTING PROCEDURE

1. Slide the sleeves with internal teeth with rubber O ring on shafts before mounting the hubs.
2. Mount the hubs with external teeth on their respective shafts flushed with the faces of hubs as shown in fig. 1.

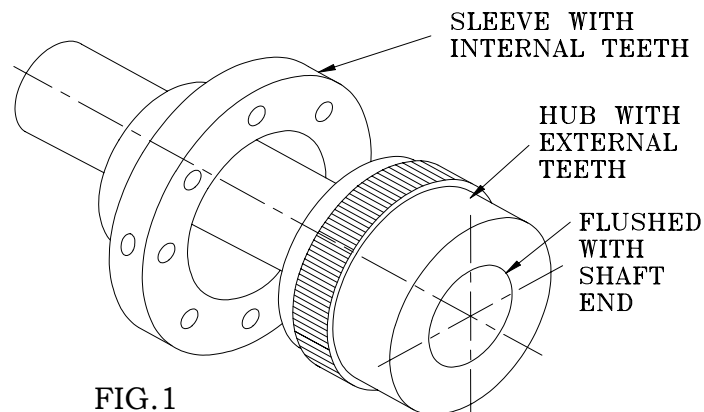

FIG.1

GEAR-FLEX COUPLING (RGD/RGS)

3. With one machine firmly bolted down, set the equipments at a distance 'G' (refer table A & B) between shaft ends by using a spacer bar equal in thickness to the required gap 'G' as shown in fig. 2.

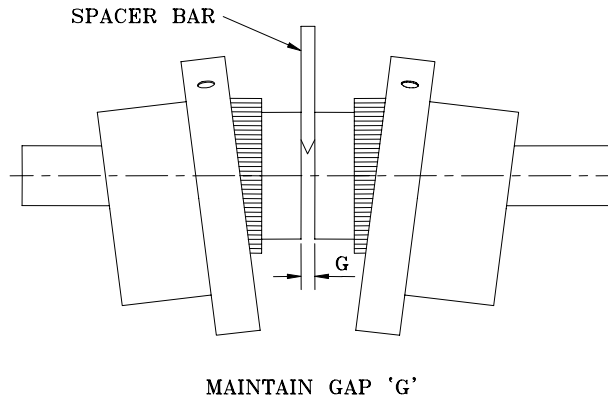

Fig.2

Deviation in standard DBSE is defined as axial misalignment (end float). For normal applications the shaft end should be flushed with inner face of the adapter. In some special cases the shaft ends may protrude beyond the inner face of the adapter or may remain inside, if required. The distance between two faces of adapter flanges is to be maintained as specified. The variation in this distance should not exceed the permissible initial axial misalignment given in table A.

GEAR-FLEX COUPLING (RGD/RGS)

(C) ALIGNMENT PROCEDURE

Alignment procedure is given separately for each type of alignment, for simplicity. However all 3 types of misalignments may be present at the same time.

IMPORTANT : The misalignment capabilities shown Table `A' & Table `B' . For optimum service from the coupling the installation misalignment (Initial misalignment) should not be more than 25% of the maximum allowable misalignments limits. Allowance should be made for any anticipated movements which will occur during operation (e.g. Thermal movements).

For Permissible *INITIAL* misalignments refer table A

For Permissible *MAXIMUM* misalignments refer table B

(I) CHECKING PARALLEL /RADIAL ALIGNMENT

Check the parallel/Radial alignment with the help of straight edge resting squarely on both the hubs at 4 places 90° apart. The deviation in the readings should not exceed the permissible initial parallel misalignment mentioned in table A. (Refer fig. 3)

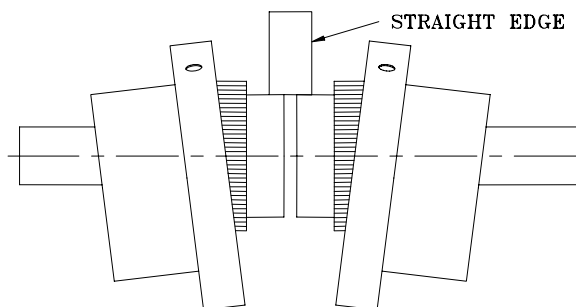

FIG.3

GEAR-FLEX COUPLING (RGD/RGS)

(II) CHECKING ANGULAR ALIGNMENT

Check the angular misalignment with the help of slip gauges by inserting in the gap at 4 places 90° apart. The deviation in the values of standard gap 'G' is Total Indicated Reading (TIR). The angular misalignment 'X' in mm is half the Total Indicated Reading. The values of angular misalignment should not exceed permissible initial misalignments mentioned in table A. (Refer fig. 4).

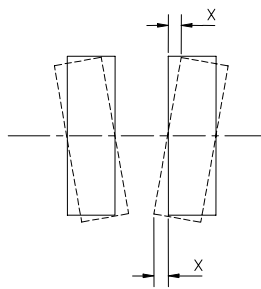

FIG. 4

(D). ASSEMBLY PROCEDURE

IMPORTANT : If the coupling is dynamically balanced, ensure that the match marks are in straight line & unidirectional before bolting the assembly.

1. Insert the gasket between the flanges. Position the flanged sleeves with lubrication plugs.
2. Insert the bolts & tighten the nuts as per tightening torque given in Table 'D'.

GEAR-FLEX COUPLING (RGD/RGS)

Remember: Assemble only with the help of the fasteners furnished with the coupling. (Refer Fig.5)

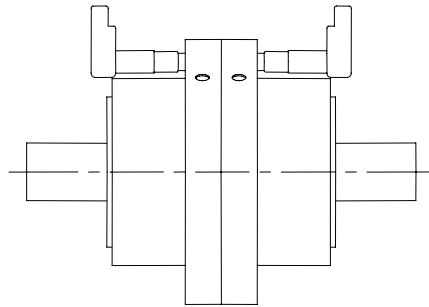

TIGHTEN THE BOLTS
Fig. 5

3. Fill with recommended grease (**RSG/RSL** with reqd. qty.) for lubrication. For grease quantity for respective coupling size, refer table No. C.
4. Change the grease after the interval of 6 months

IMPORTANT: The necessity for shields & guards varies with individual installations. The owner or user must provide the required safety guards. Safety guards or shields are not furnished by us with this equipments.

GEAR FLEX COUPLING
(RGD/RGS)

TABLE 'A'

PERMISSIBLE INITIAL MISALIGNMENTS FOR GEAR COUPLINGS
(INSTALLATION)

COUPLING SIZE	TYPE RGD				TYPE RGS			GAP 'G' Std (mm)
	ANGULAR		PARALLEL/ RADIAL 'P' (mm)	AXIAL (mm)	ANGULAR		AXIAL (mm)	
	Degrees per gear mesh	'X' (mm)			Degrees per gear mesh	'X' (mm)		
10	$\pm 0.5^\circ$	0.3	0.2	± 0.125	± 0.125	0.2	± 0.125	3
15		0.5	0.2			0.2		3
20		0.5	0.3			0.2		3
25		0.6	0.3			0.3		5
30		0.7	0.4			0.3		5
35		0.8	0.4			± 0.25		0.4
40		0.9	0.5	0.5	6			
45		1.0	0.5	0.5	8			
50		1.1	0.7	0.5	8			
55		1.2	0.7	0.6	8			
60		1.3	0.8	0.7	8			
70		1.5	0.8	0.8	10			

- Half Flexible Gear Couplings Type RGS cannot accommodate parallel misalignment. Gap 'G' in the above table is given when angular & axial misalignments are zero.

**GEAR FLEX COUPLING
(RGD/RGS)**

TABLE 'B'

**PERMISSIBLE MAXIMUM MISALIGNMENTS FOR GEAR COUPLINGS
(OPERATION)**

COUPLING SIZE	TYPE RGD				TYPE RGS			GAP 'G' Std (mm)
	ANGULAR		PARALLEL/ RADIAL 'P' (mm)	AXIAL (mm)	ANGULAR		AXIAL (mm)	
	Degrees per gear mesh	'X' (mm)			Degrees per gear mesh	'X' (mm)		
10	± 2°	1.1	0.6	± 0.5	± 1°	0.6	± 0.5	3
15		1.4	0.8			0.7		3
20		1.8	1.0			0.9		3
25		2.2	1.2			1.1		5
30		2.6	1.4			1.3		5
35		3.0	1.7			1.5		6
40		3.6	2.0	1.8	6			
45		4.0	2.1	2.0	8			
50		4.3	2.6	2.2	± 1	8		
55		4.7	2.9	2.4	8			
60		5.2	3.2	± 2	2.6	± 2	8	
70		6.0	3.7	3.1	10			

- Half Flexible Gear Couplings type RGS cannot accommodate parallel misalignment. Gap 'G' in the above table is given when angular & axial misalignments are zero.

**GEAR FLEX COUPLING
(RGD/RGS)**

TABLE 'C'

**GREASE FOR GEAR COUPLING
(RGD/ RGS)**

Sr. No.	COUPLING SIZE	GREASE QTY. (Kg)	
		RGD	RGS
1	10	0.03	0.015
2	15	0.06	0.030
3	20	0.17	0.085
4	25	0.23	0.115
5	30	0.34	0.170
6	35	0.45	0.225
7	40	0.79	0.395
8	45	1.08	0.540
9	50	1.89	0.945
10	55	1.93	0.965
11	60	3.46	1.730
12	70	6.35	3.175

RECOMMENDED GREASE – RATHI SPECIAL GREASE (RSG) ($\delta g = 910 \text{ Kg/m}^3$)
 - ESSO - HMP OR
 BEACON 2 OR 3
 - INDIANOIL – SERVOGEM 2

TABLE 'D'

**TIGHTENING TORQUE FOR GEAR COUPLING FLANGE BOLT
(RGD/ RGS)**

Sr. No.	COUPLING SIZE	FLANGE BOLT TORQUE (Nm)
1	10	28
2	15	28
3	20	97
4	25	132
5	30	132
6	35	244
7	40	244
8	45	244
9	50	477
10	55	477
11	60	477
12	70	576