

DO NOT SCALE IF IN DOUBT ASK

ITEM No.	DESCRIPTION	QUANTITY	DRAWING / PART No.
1	HUB 195 EFLEX	1	NE19PH
2	CAPSCREW M12 x 90 SOCKET HEAD	12	M1290SC
3	FLANGED BUFFER BUSH	12	NE19FB
4	BUFFER 46D SHORE (ARNITEL)	12	NE19BA
5	WASHER M12 PLAIN	24	NE19PW
6	LOCKNUT M12 NYLOC	12	M12NL
7	SPACER	1	E19SD0623/98
8	FLANGE BOLT IG25/IG30	6	IG25FBM
9	SPIGOT RING	1	E19SD0360/97
10	LOCKNUT 5/8" UNC GRADE C	6	I625UNCSL
11	RIGID HUB IG25	1	IG25RH

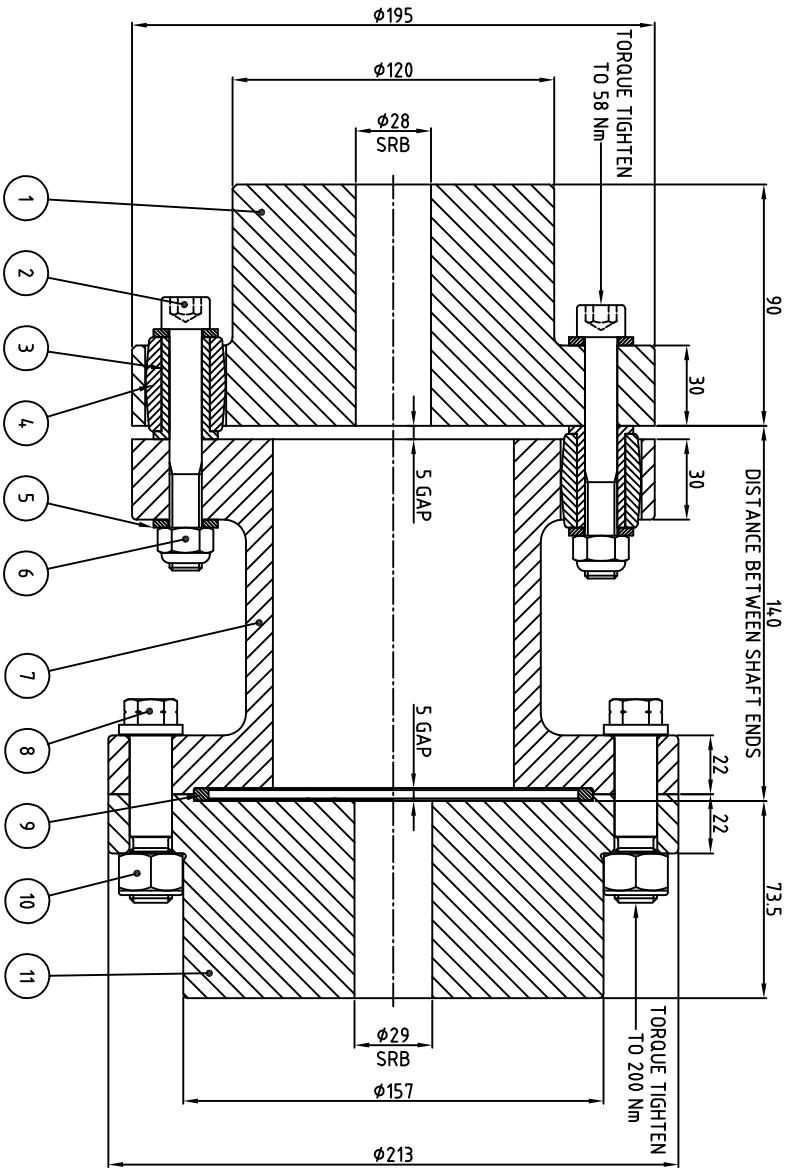

PART NUMBER:- NES195/L14.0/F12/00

REV	DESCRIPTION	DATE	BY	CHK	APP
1	ISSUED FOR MANUFACTURE				
2	REVISION				
3	REVISION				
4	REVISION				
5	REVISION				
6	REVISION				
7	REVISION				
8	REVISION				
9	REVISION				
10	REVISION				
11	REVISION				

UNLESS OTHERWISE STATED
 ALL DIMENSIONS IN MILLIMETRES
 ALL MACHINED SURFACES TO BE SQUARE AND CONCENTRIC
 ALL SURFACES MACHINED $3.2 / (125)$ MAX
 ISO METRIC THREADS TO BS3643 / CLASS 6H/6g FIT
 UNDESIGNED RADIUS TO BE 0.0mm (0.032")
 B.S. SPECS COMPLY WITH LATEST ISSUE



DESIGNER	PAULINE
APPROD	
SCALE	1:1
PRODUCTION	
DRAWN	

DESCRIPTION	195/F12 STEEL EFLEX SPACER COUPLING 140mm D.B.S.E
DATE	NES195/L14.0/F12/00-B