



Torsionally soft coupling

An Industrial coupling having 'VARYING STIFFNESS CHARACTERISTIC'

No need of lubrication

Versatility of application - can be used with SHAFT TO SHAFT or SHAFT TO FLANGE arrangement

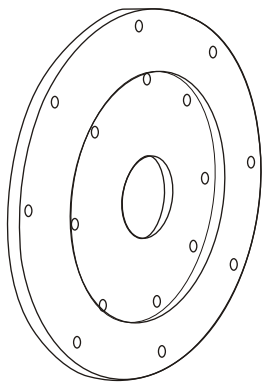

FLYWHEEL PLATE

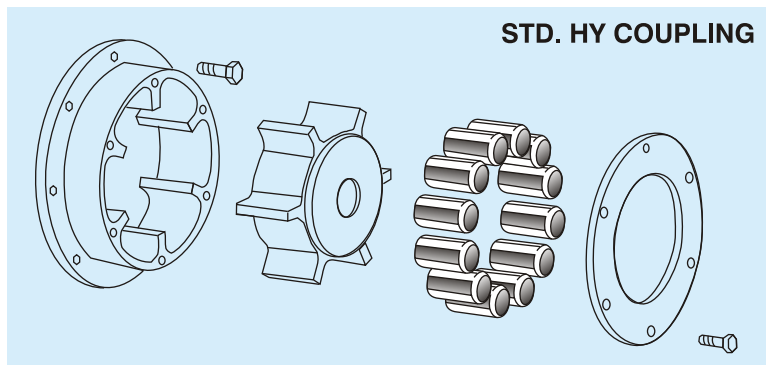

Low initial & operational cost

Smooth power transmission

Compact size

Effective damping of vibrations

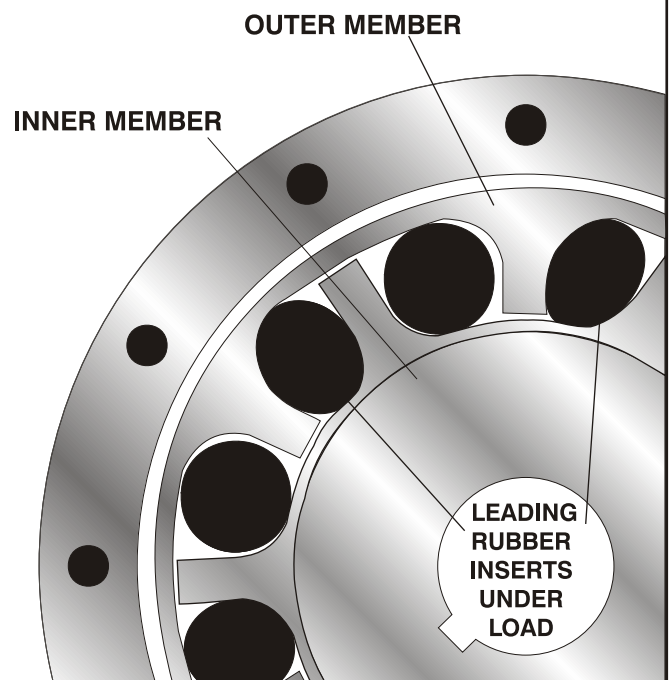

SELECTION PROCEDURE

(a) Service Factor

Determine appropriate SERVICE FACTOR for driving & driven machine (SF1 & SF2) from service factor table.

(b) Design Power

Application power x (SF1 + SF2)

(c) Coupling Size

Refer 'DIMENSIONAL DATA' table for coupling rating & select a coupling size for which power is equal to or greater than DESIGN POWER.

(d) Bore & Flywheel Plate Size

Refer 'DIMENSIONAL DATA' table to check that the required bores & flywheel plate can be accommodated.

EXAMPLE

A coupling is required to transmit 800 kW at 1000 rpm from a 6 cylinder diesel engine to a centrifugal pump. Engine flywheel size is SAE 21" & pump shaft dia. is 145 mm.

(a) Service Factor

SF1 = 1.7, SF2 = 1.25

(b) Design Power

800 x (1.7+1.25) = 2360 kW / 1000 rpm.

(c) Coupling Size

HY - 3860

(d) Bore & Flywheel Plate Size

Max. bore of a std. **HY-3860** is 170 mm, which is higher than pump shaft dia. & flywheel plate of SAE 21" size is also available. Hence selection is OK.

ORDERING EXAMPLE

For above example order should be placed as **HY - 3860 TYPE B (SAE 21")**

SERVICE FACTOR TABLE

Driver Machine (SF1)	Driven Machine (SF2)	
Diesel Engine	Blower	Pump
1 Cylinder 3.5	Centrifugal 1.5	Centrifugal 1.25
2 Cylinder 3.0	Lobe or vane 2.0	Gear 2.0
3 Cylinder 2.5	Compressor	Ram 3.0
4 Cylinder 2.0	Axial screw 1.5	Reciprocating 3.0
5 Cylinder 1.8	Centrifugal 1.5	Fan
6 Cylinder 1.7	Lobe type 2.0	Centrifugal 1.5
More than 6 Cylinder 1.5	Reciprocating 3.0	Mine ventilating 2.5
Vee Engine 1.5	Rotary 2.0	Propeller marine 2.0
Petrol Engine 1.5	Conveyor	Machine tool 2.0
Electric Motor/Turbines 0	Belt, chain & screw 1.5	Cement mill 2.5
	Bucket 2.0	Alternator/Generator 1.5
		Generator - Welding 2.2

WEIGHT & INERTIA DETAILS

Size	STD. HY COUPLING		ADAPTER		FLYWHEEL PLATE		
	Wt (kg)	MI (kgm ²)	Wt (kg)	MI (kgm ²)	SAE Size (inch)	Wt (kg)	M.I. (kgm ²)
HY - 50	3.7	0.0095	4.7	0.0103	6.5	2.0	0.012
HY - 120	6.8	0.0275	7.8	0.0262	8	3.0	0.027
HY - 200	9.5	0.049	12.2	0.05	10	6.5	0.083
HY - 240	12.1	0.0704	17.0	0.08	11.5	8.2	0.128
HY - 370	16.1	0.1224	22.5	0.13	14	19.5	0.54
HY - 730	28.0	0.2954	30	0.23	18	29.2	1.2
HY - 1150	42.9	0.566	39	0.38	21	50.6	2.9
HY - 2150	69.3	1.308	82	1.2	24	74.0	4.9
HY - 3860	116.5	3.16	124	2.5			
HY - 5500	172.1	5.81	228	6.3			

● Weight & M.I. are at min. bores.

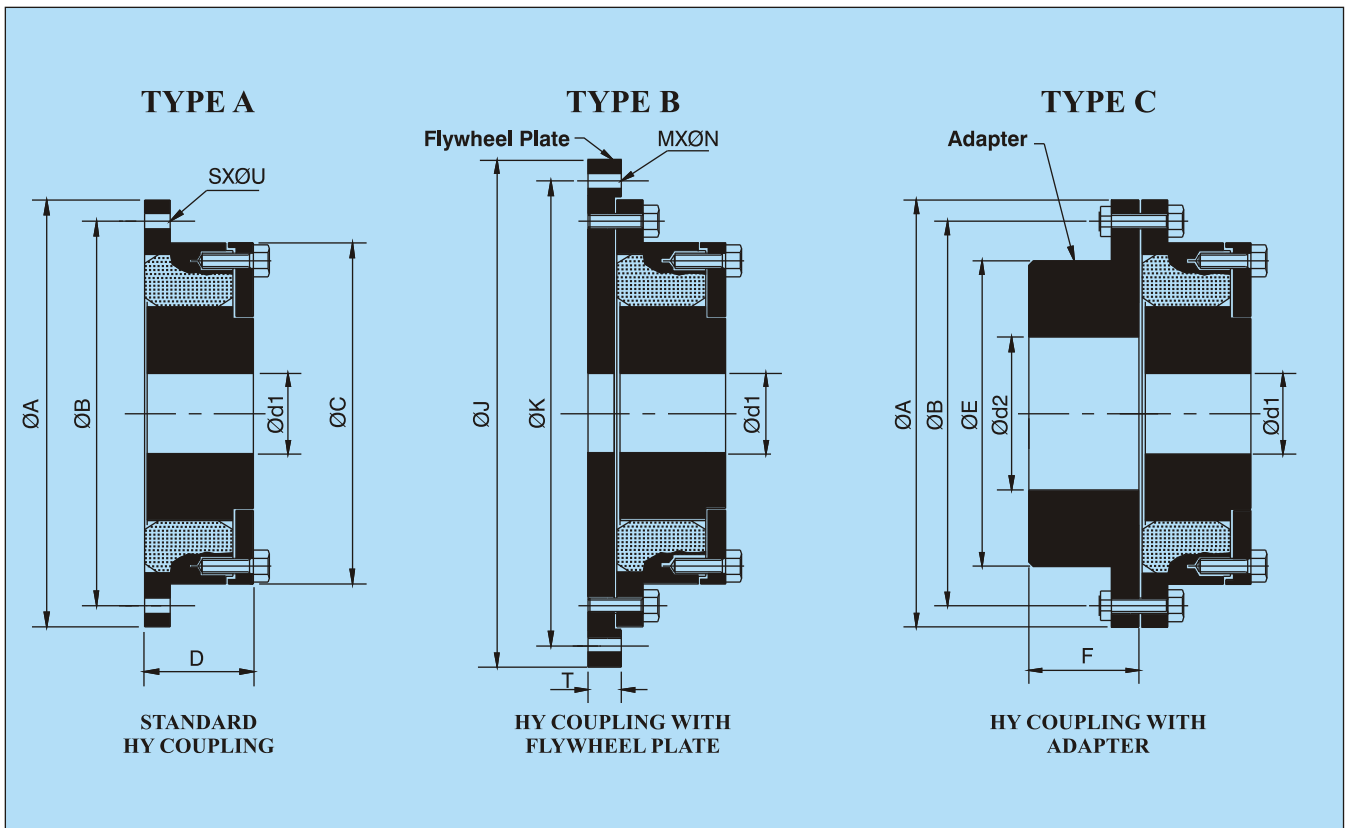

DIMENSIONAL DATA

Coupling Size	Coupling rating per 100 rpm		Max. Speed rpm	Min. Bore	Max. Bore		ØA	ØB	ØC	D	ØE	F	SXØU	NO. OF RUBBER INSERTS PER COUPLING
	HP	.kW			Ød1	Ød2								
HY-50	6.3	4.7	5550	15	40	65	158.7	138.1	122	47	111	55	6 X 9.2	10
HY-120	13.4	10.0	4350	30	55	75	200.0	177.8	158	51	127	65	6 X 9.2	10
HY-200	20.8	15.5	3950	35	70	90	222.2	200.0	180	54	155	75	6 X 9.2	12
HY-240	24.8	18.5	3700	40	75	100	238.1	212.7	188	60	175	85	6 X 11.2	12
HY-370	38.2	28.5	3400	40	85	110	260.3	235.0	212	68	190	95	8 X 11.2	12
HY-730	76.7	57.2	3000	55	95	120	308.0	279.4	255	90	205	102	8 X 13.2	12
HY-1150	117.3	87.5	2600	55	115	130	358.8	323.8	298	99	220	110	10 X 13.2	12
HY-2150	219.2	163.5	2400	70	140	175	425.4	390.5	365	120	298	150	16 X 13.2	12
HY-3860	396.3	295.6	2250	80	170	200	508.0	469.9	440	134	340	170	12 X 17.25	14
HY-5500	587.2	438.0	1950	90	210	250	577.8	536.6	506	147	425	210	12 X 17.25	16

FLYWHEEL PLATE DETAILS

Flywheel Plate SAE Size (inch)	6.5	8	10	11.5	14	18	21	24
Suitable Coupling Size	HY-50	HY-50 HY-120 HY-200	HY-120 HY-200 HY-240	HY-240 HY-370 HY-730	HY-370 HY-730 HY-1150	HY-1150 HY-2150 HY-3860	HY-2150 HY-3860 HY-5500	HY-3860 HY-5500

Flywheel Plate SAE Size (inch)	6.5	8	10	11.5	14	18	21	24
ØJ	215.9	263.53	314.3	352.4	466.7	571.5	673.1	733.4
ØK	200.03	244.48	295.27	333.38	438.15	542.92	641.35	692.15
MXØN	6 X 8.33	6 X 10.5	8 X 10.5	8 X 10.5	8 X 13.5	6 X 16.7	12 X 16.7	12 X 22.0
T	8	8	12	12	16	16	20	24

RATED TORQUE, MISALIGNMENT & STIFFNESS DETAILS

Coupling Size	HY-50	HY-120	HY-200	HY-240	HY-370	HY-730	HY-1150	HY-2150	HY-3860	HY-5500
Rated Torque (Tr) (Nm)	449	955	1480	1767	2722	5462	8356	15613	28228	41826
Allowable Vibratory Torque (At 10 Hz) (Nm)	55	125	190	225	347	673	1066	1990	3565	5080
Allowable misalignment										
Axial (mm)	0.75	1.5	1.5	1.5	1.5	1.5	1.5	2.0	3.0	3.0
Radial (mm)	0.75	0.75	0.75	0.75	0.75	1.0	1.5	1.5	1.5	1.5
Angular (Deg.)	0.5	0.5	0.5	0.5	0.5	0.5	0.5	0.5	0.5	0.5
Radial stiffness* (N/mm)	1522	1811	2264	2552	2867	3771	4142	5123	6677	8443
Axial stiffness* (N/mm)	531	648	786	883	1003	1311	1452	1792	2323	2945
Torsional Stiffness* (kNm / RAD)										
At 0.25 Tr	3.501	8.12	13.45	17.79	24.62	46.78	71.37	132.04	265.07	465.05
At 0.5 Tr	4.746	11.08	18.24	23.84	33.54	63.57	96.97	180.07	360.05	622.0
At 0.75 Tr	6.545	15.21	25.12	32.54	46.16	87.75	134.03	248.02	498.01	846.3
At 1 Tr	9.123	21.21	35.01	44.95	64.42	121.02	187.01	346.02	695.07	1150.3

* for HSZ - 70

ELASTOMER INFORMATION

Rathi manufactures rubber elements to high quality control standards. Well equipped laboratory with wide range of specialised equipment maintains consistent quality. Specialised compounds can be developed in our laboratory to meet specific requirements.

'Rathi' Standard rubber compounds with their peculiarities are as follows.

Elastomer Grade	HSZ	HRZ	HCZ	HNZ
Identification Mark	GREEN	RED	YELLOW	WHITE
Resistance to Compression Set	GOOD	GOOD	FAIR	GOOD
Resistance to Flexing	GOOD	EXCELLENT	GOOD	GOOD
Resistance to Cutting	FAIR	EXCELLENT	GOOD	GOOD
Resistance to Abrasion	GOOD	EXCELLENT	GOOD	GOOD
Resistance to Oxidation	FAIR	FAIR	VERY GOOD	GOOD
Resistance to Oil & Gasoline	POOR	POOR	EXCELLENT	EXCELLENT
Resistance to Acids	GOOD	GOOD	FAIR	FAIR
Resistance to Water Swelling	GOOD	GOOD	GOOD	GOOD
Service Temp. Maximum; Continuous	100°C	80°C	100°C	120°C
Service Temperature Minimum	-40°C	-50°C	-30°C	-40°C

- All dimensions are in mm, unless otherwise specified.
- Initial misalignment should not exceed 25% of maximum allowable misalignment.
- Coupling should be dynamically balanced for operation above 80% of declared maximum coupling speed.
- Standard rubber elements supplied would be 'HSZ - 70'.

• In view of our constant endeavour to improve the quality of our products, we reserve the right to alter or change specifications without prior notice.

• This document is an intellectual property of Rathi Transpower Pvt. Ltd. and subject to copyright.



Rathi Transpower Pvt Ltd

Rathi Chambers, 7, Deccan College Road,
Pune 411 006.(INDIA)
Phone : 91-20-30517201
Fax : 91-20-30517212
E-mail : enquiry@rathigroup.com
Website : www.rathicouplings.com

Distributor